

APPLICATION REPORT



Written by Klaus Rupp, Harald Faber & Hans-Jörg König, Schenck Process GmbH

At a glance: feeding alternative fuels

1 Introduction

Firing of alternative fuels becomes more and more important in Power Generation. Even by substitution of increasingly expensive coal or by use as a greenhouse gas neutral fuel the amount of alternative fuel will grow. Not only in the European Community but in a multiplicity of countries in future firing alternative fuels will be prescribed by regulations. Most of the existing boilers can run with and the design of new ones already allows the use of alternative fuels. As an additional advantage alternative fuels have a high calorific value that can even exceed the heat value of hard coal (20 MJ/kg). This is accompanied by a reduction in CO₂ emissions, which makes an important contribution to environmental protection.

The use of an alternative fuel is predominantly determined by local availability. The plant operator must therefore first give serious consideration to the suitability of materials for use in the burning process, production of emissions and capital and operating costs for handling alternative fuels. The alternative fuels that are available can have widely differing properties. These properties place particular demands on the metering technology, storage and transport. This article examines the requirements for using solid alternative fuels and how they can be met.



Fig. 1 Examples of solid alternative fuels and impurities (bottom right)

2 Alternative fuels

As a rule alternative fuels come from different sectors of industry and may have highly varied materials properties. Nowadays this typically involves for Power Plants biomass, such as wood chips/wood pellets/saw dust, sewage sludge and animal meal or paper, packaging wastes and shredded plastic waste for Waste Incineration Plants (» Fig. 1). Many of these materials require mechanical processing by shredding, screening and separating to obtain a homogenised product with a specifiable calorific value. As a rule processing is not carried out at the power plant but is undertaken by specialist processing firms that then arrange supply contracts with the power plant in the region (» Fig. 2). When compared with primary fuels a great many

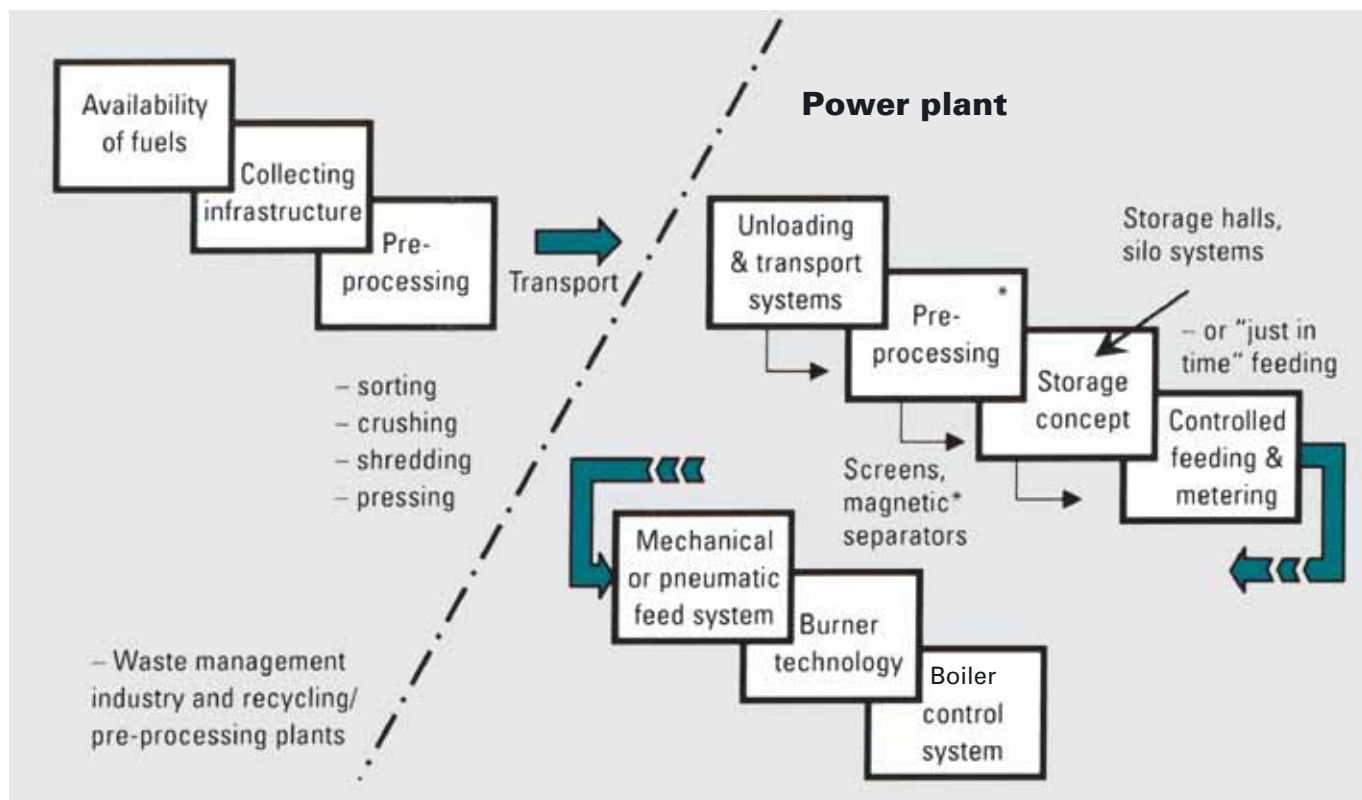

Fig.2 Diagram showing utilisation of alternative fuel

alternative fuels have bulk densities that are only 10 to 20% of the density of a primary fuel, which means that large volumes have to be transported, stored and metered. At the very common fuel throughput of 5 – 30 t/h, as much as 1000 – 6000 m³ may have to be handled a day. Transport and storage costs are therefore major factors when considering economic viability.

3 Equipment

3.1 Storage

Storing an alternative fuel is taken to mean acceptance of the material as well as its storage. A distinction is made in principle between the approaches of “just-in-time” and intermediate storage. “Just-in-time” implies direct supply of the material from lorries to the process, which can take place through docking stations or container tipping stations. With intermediate storage the fuel is stored in silos, flat-bottomed hoppers or containers before it is introduced into the process. If necessary intermediate storage can also take place in containers that are resistant to pressure surges.

3.1.1 Bulk reception unit

Schenck Process’ IntraBulk® bulk reception unit is an effective and economical solution for material acceptance (» Fig. 3). It can be fed from road vehicles or loaders and does not require any ground excavations or expensive civil engineering. Depending on the product characteristics, the discharge capacities can be in excess of 500 t/h. From the bulk reception unit the alternative fuel is directly introduced into the process by a trough chain conveyor. The chain conveyor’s feed is controlled by the reception unit. Depending on the plant setup, the bulk reception unit can also be used to feed any other storage facility.

3.1.2 Walking floor containers

Nowadays solid alternative fuels are also often supplied in bulk in semitrailers with walking floor discharge systems. These trailer systems are used worldwide and have been developed specifically for transporting up to 90 m³ of bulk material. The semitrailer is backed into the exact unloading position in front of the docking station. An inflatable sealing system encloses the trailer on all sides with a dust-tight seal so that no material can escape into the atmosphere during the unloading. The tractor unit is then uncoupled from the trailer and the walking floor extraction system is connected to a hydraulic plant (» Fig. 4).

The elements of a walking floor container only move in a predetermined rhythm – simultaneously in the direction of the screw extractor floor, and separately in the return direction – and use this sequence of movements to unload

the trailer, trough docking stations or container tipping stations. With intermediate storage, the fuel is stored in silos, flat-bottomed hoppers or containers before being introduced into the process. If necessary intermediate storage can also take place in containers that are resistant to pressure surges. A safety switch cuts off the hydraulic system if there is too much material in the screw extractor floor and switches it back on again once the hydraulic pressure has fallen to an appropriate level. The screw extractor floor, which is an integral part of the docking station, transports the alternative fuel into the troughed chain conveyor that usually follows. The inlet cross-section must be made large enough to prevent the material from bridging over the screw extractor floor and to ensure a constant feed of material into the troughed chain conveyor. For many alternative fuels a single screw is not sufficient. As a rule there are four screws and either all four screws or only one pair of screws are used depending on the transport rate required.



Fig. 3 IntraBulk® bulk reception unit



Fig. 4 Docking station with walking floor container



Fig. 5 Docking station with tipped container



Fig. 6 Silo extraction screw



Fig. 7 Crane hall

3.1.3 Tipping containers

Standard containers can also be used instead of walking floor containers to store the material. These containers are driven to the tipping station by the tractor unit and are unloaded into the screw extractor floor by controlled tipping of the container. However, the smaller volume of only about 40 m³ makes increased demands on logistics and must be taken into account when deciding whether to use a standard container (» Fig. 5).

3.1.4 Storage silos

Solid fuels can also be held in storage silos. This guarantees longer availability in the power plant. Storage silos are particularly appropriate where there is a poor infrastructure or for bulk materials that are difficult to extract, such as animal meals. The alternative fuel is then stored in appropriately dimensioned silos from where it is introduced into the process. The extraction from the silo must be reliable and controlled to ensure a constant supply. One suitable extraction system is a silo emptying screw that circulates inside the silo immediately above horizontal silo floor. The screw carries the alternative fuel to the centre of the silo floor where extraction takes place (» Fig. 6). An agitator, rotating horizontally, can also be used to enable the material to discharge with ease. The silo can be made from steel or concrete. Bridging can be practically eliminated if silos with vertical walls are used. Ripper teeth, which if necessary can be made wear-resistant, are usually fitted to the spirals to assist with the extraction of material.



Fig. 9 Tube belt conveyor from TEDO, Schenck Process Group

3.1.5 Crane halls

Instead of storing the alternative fuel in silos it can also be held in a crane hall (» Fig. 7). The advantages of this include the enormous storage volume and scope for mixing different materials. The fuel is brought by a crane from the hall into storage boxes, equipped with walking floors. From there the material is introduced into the process.

3.2 Metering

The different types of alternative fuels place heavy demands on the metering equipment, which has to be designed to cope with a wide range of material properties, such as particle size, composition, bulk density, flow characteristics, etc. Accurate and constant metering of the alternative fuels is necessary to ensure a consistently fuel feeding. The metering systems must also be extremely reliable and be able to function smoothly even with materials that contain foreign bodies and oversized particles. The metering equipment must be easy to integrate into existing plants and require as little maintenance as possible. Various metering systems and the additional equipment that is required for reliable metering are described below.

3.2.1 Chain conveyors

Chain conveyors are used for transporting materials over limited distances in vertical, horizontal or inclined directions (» Fig. 8). The conveyors are dust-proof, low-maintenance and reliable and their speed can be controlled. When adapted to suit the widely differing conveying rates and materials these conveyors have proved to be suitable for dispensing material to belt weighfeeders. The MoveMaster® chain conveyors used by Schenck Process usually feature a monitoring system to detect chain breakage.

3.2.2 Tube belt & U belt conveyors

Tube belt & U belt conveyors are used for transporting materials over long distances. The TEDO conveyors are able to handle problematic topographies and distances of up to 5000 m at feed rates of up to 900 m³/h. Depending on the feed rate the tube diameter varies between 180 and 500 mm.

3.2.3 Magnetic separators

Magnetic separators are used to remove pieces of iron from the flow of material to prevent damage to the downstream metering and conveying equipment and avoid possible blockages in the delivery line to the rotary kiln and/ or calciner burners. The alternative fuel is passed through a magnetic drum and the pieces of iron that have been removed are ejected automatically into a waste bin. The cleaned fuel is then transported onwards through a chute.

3.2.4 Star screen

A star screen in a plant for handling alternative fuels has the task of reliably protecting downstream equipment from disruptive materials. These machines do not perform a classifying function in the strict sense of the word but are only used to remove oversized disruptive materials to varying extents from the flow of material (» Fig. 10). The cut-off size is determined by the geometry of the screening stars and by the rotational speed of the screening shafts. During operation the cut-off size can be varied within certain limits by adjusting the rotational speed of the screening shafts. The disruptive materials are transported over the entire screen deck into a waste bin, while the “good” material passes between the screening shafts over the full length of the screen.



Fig. 8 MoveMaster® chain conveyor

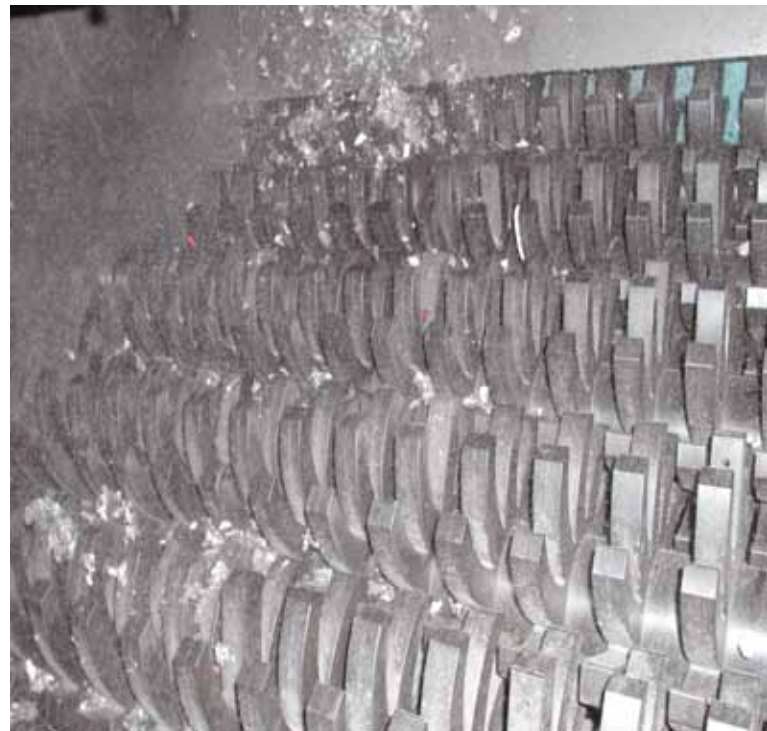

Fig. 10 Screen deck of star screen

4. Weighing equipment

The weighing equipment is the key component in the control system of any plant for handling solid alternative fuels. The associated control loop controls not only the belt speed of the weighing unit itself but also the speeds of the upstream feed conveyors, such as troughed chain conveyors and screw extractor floors. This ensures constant loading, which is a basic requirement for high-accuracy weighing of a flow of material, and prevents the weighing unit and downstream blowthrough rotary vane feeder from being overloaded. Accurate metering is an essential precondition for pulsation-free delivery of the fuel to the boiler and generating power with the lowest possible emissions.

4.1 Belt weighfeeder

The MULTIDOS® belt weighfeeders used are specifically designed for metering solid alternative fuels and are therefore particularly suitable for the above requirements. The belt weighfeeders are used for almost all types of alternative fuel. Because of the distances between the centres and belt widths available, they can be adapted to suit very varied conveying distances and rates and are relatively easy to integrate into existing plants. The material originating from the feeders is transported onwards and weighed directly on the weigher, which virtually eliminates any backing up of material. The low bulk density of alternative fuels is taken into account through the use of a very lightweight, high-strength antistatic belt as well as

an extended weighing bridge. The ratio of material being measured to the tare weight on the weighing bridge is greater than 1 – an important precondition for achieving high metering accuracies. The belt weighfeeders used are completely enclosed and are fitted with discharge hoods with connecting flanges for dedusting purposes (» Fig. 11).

4.2 Screw weighfeeder

Like belt weighfeeders, the MultiFlex screw weighfeeder used by Schenck Process undertakes continuous gravimetric metering of the stream of material. The MultiFlex is completely enclosed (dust-proof) and is resistant to pressure surges. The bulk material in a screw conveyor is weighed, its flow rate is determined and the flow of material being conveyed is continuously corrected on the basis of the measured value by the rotational speed of the screw (» Fig. 12). The measured transport rate is checked at a higher level on the basis of the loss in weight in the complete weigher including the feed hopper. Any deviations are corrected automatically. The screw weighfeeder is equipped with a double screw to ensure a large inlet cross-section to the screws.

5. Material transport to the burner

5.1 Mechanical conveyance

The alternative fuel can be conveyed mechanically or pneumatically. Mechanical conveyance tends to take place in troughed chain conveyors. Another option is to use belt

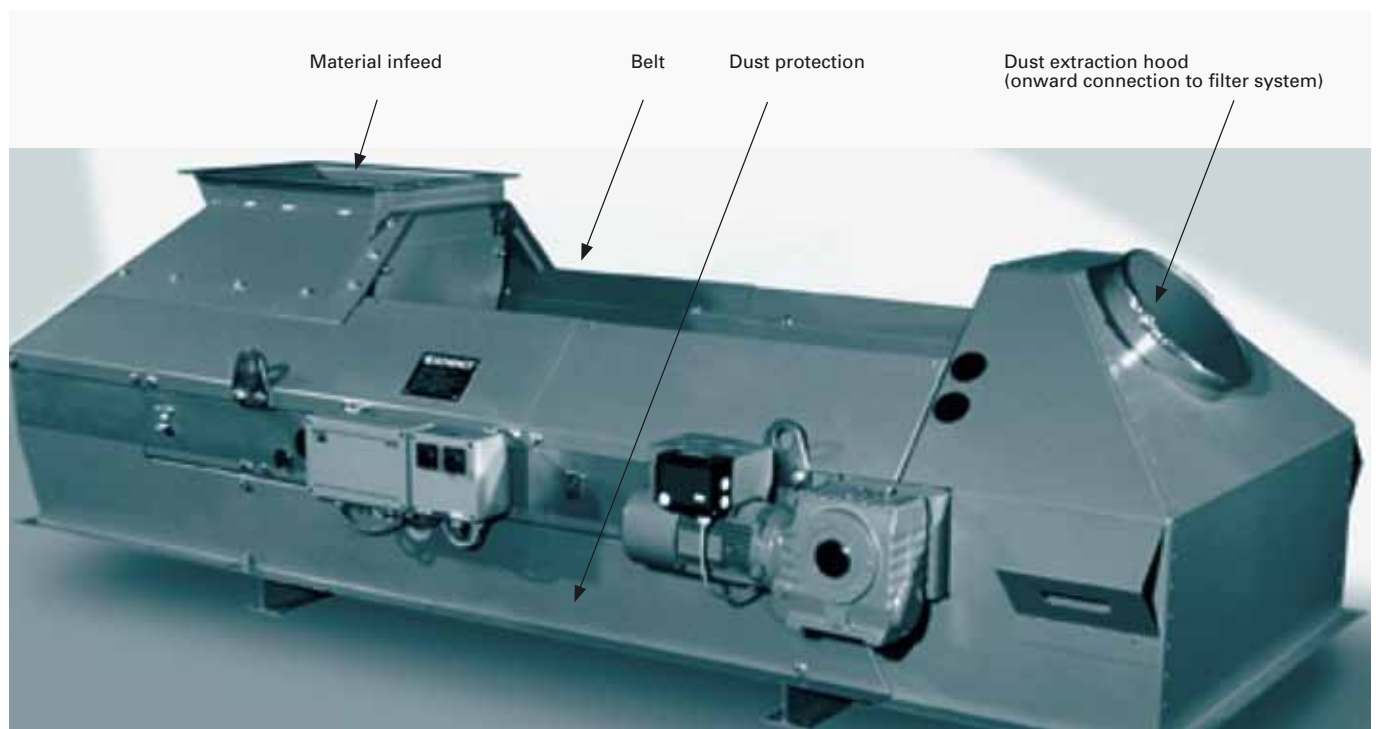

Fig. 11 MULTIDOS® weighfeeder

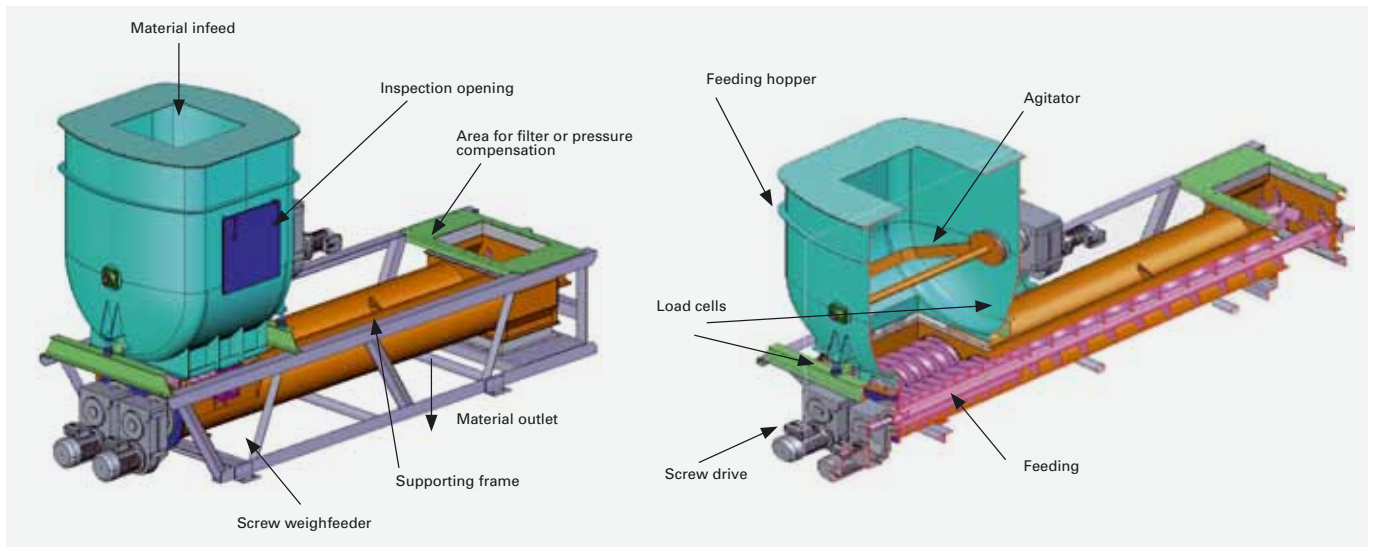

Fig. 12 MultiFlex screw weighfeeder

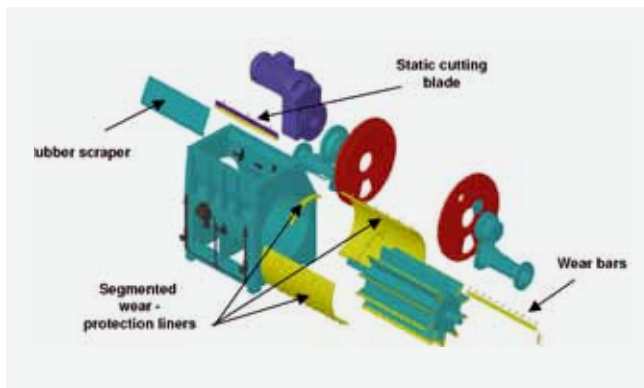

Fig. 13 IDMS rotary vane feeder

conveyors. One advantage of mechanical conveyance lies in the trouble-free transport of lumpy materials while the disadvantages include comparatively high capital costs and poor flexibility.

5.2 Pneumatic conveyance

Pneumatic conveyance, on the other hand, can be integrated relatively easily into existing plants. The pneumatic conveyor is designed using a specially developed design program.

After inputting the basic data, i.e. the vertical and horizontal conveyance distances, number of bends, rate of conveyance and pressure drop of the burner, the program calculates the internal diameter required for the delivery line, the fan pressure needed and the necessary air volume. When the delivery lines are installed, any requirements such as sufficiently large bend radii, smooth joints in the pipelines and the specification of wear-protection linings in the bends then need fulfilling.

5.3 Blow-through rotary-vane feeder

An injector blow-through measuring rotary-vane feeder (IDMS) can be used to feed the alternative fuel into the pneumatic delivery line. This feeder was developed at Schenck Process and adapted specifically to suit the requirements of metering solid alternative fuels. The blow-through rotary-vane feeder is a vertical rotary vane feeder in which bulk material discharge is achieved by forced clearance of the compartments between the rotary vanes using transport air from the pneumatic conveyance system that has been accelerated by the injector (» Fig. 13). A blade, which cuts up oversized particles as well as foreign bodies, is positioned in the inlet shaft in the direction of rotation of the cellular rotor.

One important criterion for successful use of a rotary vane feeder is its service life. The blow-through rotary-vane feeder is protected from wear by wear strips attached radially and axially to the cellular rotor using screws. The radial wear strips can be replaced without dismantling the entire feeder and even replacement of the axial strips does not require any additional adjustment work. The casing of the blow-through rotary-vane feeder itself as well as the purging channel are also protected against wear. Given the low level of wear over a long period, this feeder, with its hard seal, ensures a highly constant volume of leakage air. It is well known that an increase in the volume of leakage air in a blow-through rotary valve causes poorer filling of the chambers and a reduction in the transport rate. The pneumatic conveyance system then becomes unstable due to the falling velocity of the air and blockages can occur in the delivery line. The blow-through rotary-vane feeder developed by Schenck Process is designed for a service life of a year, even with high pressures in the delivery line – a value that is not as a rule achieved by conventional, soft-sealing feeders.

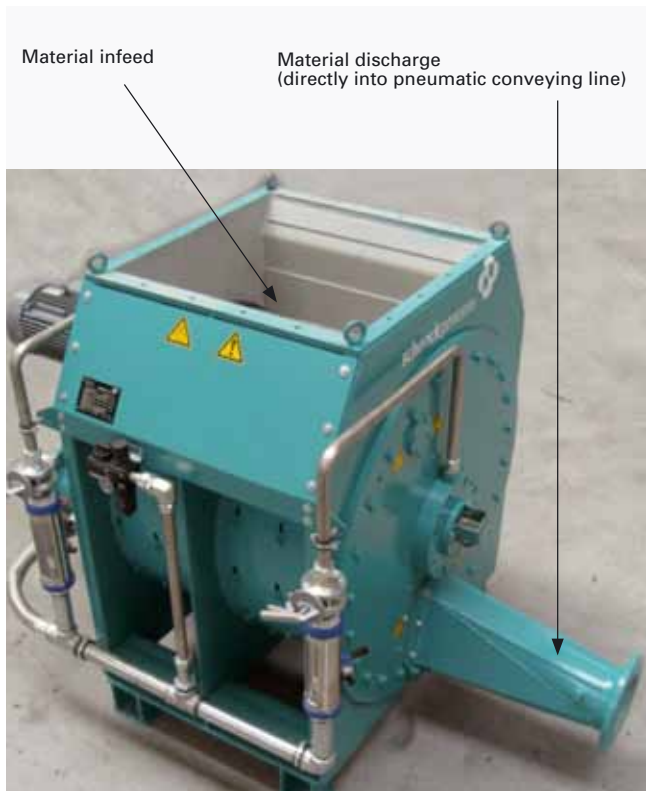

Fig. 13 IDMS rotary vane feeder

The active blast through the chambers of the cellular rotor means that a blow-through feeder achieves greater operational reliability than any normal discharge feeder, especially with adhesive materials.

The blow-through feeder described here is available in two sizes for maximum volume throughputs of 80 and 150 m³/h respectively. This feed principle has even been used successfully for the pneumatic conveyance of animal meals.

6 Conclusion

The availability of good quality alternative fuels is most probably going to decrease in the future and we will see increased use of new alternative fuels with different flow properties. This means that the demands of handling alternative fuels will increase still further. The metering systems must be designed for widely varying materials and the plants themselves must be protected from foreign bodies, damage as well as blockages. These requirements can only be met if all a plant's components have been carefully matched to one another.

As a general supplier, Schenck Process rises to this challenge. The core components have been developed at Schenck Process, namely the weighing units of the MultiFlex screw weighfeeder and the MULTIDOS® weighfeeder, the IDMS rotary vane feeder, the MoveMaster® trough chain conveyors, the tube belt conveyors from TEDO, the IntraBulk® bulk reception unit as well as discharge screws and storage bins with integrated agitators. For the remaining equipment, Schenck Process is in close contact with well-known manufacturers. Schenck Process is prepared to deliver complete plants including engineering and steel works as a turnkey. In addition, Schenck Process owns a test field where new developments can be tested, new materials can be checked with regards to flow behaviour and Schenck equipment can be seen in operation.



Schenck Process GmbH
 Marketing Communication
 Pallaswiesenstr. 100
 64293 Darmstadt, Germany
 T +49 61 51-15 31 29 87
 F +49 61 51-15 31 27 54
 press@schenckprocess.com
 www.schenckprocess.com